

Please check the examination details below before entering your candidate information

Candidate surname

Other names

Centre Number

Candidate Number

Pearson Edexcel
Level 1/Level 2 GCSE (9–1)

--	--	--	--	--

--	--	--	--

Monday 8 June 2020

Morning (Time: 1 hour 30 minutes)

Paper Reference **1MA1/3F**

Mathematics

Paper 3 (Calculator)

Foundation Tier

You must have: Ruler graduated in centimetres and millimetres, protractor, pair of compasses, pen, HB pencil, eraser, calculator. Tracing paper may be used.

Total Marks

Instructions

- Use **black** ink or ball-point pen.
- **Fill in the boxes** at the top of this page with your name, centre number and candidate number.
- Answer **all** questions.
- Answer the questions in the spaces provided – *there may be more space than you need.*
- You must **show all your working**.
- Diagrams are **NOT** accurately drawn, unless otherwise indicated.
- **Calculators may be used.**
- If your calculator does not have a π button, take the value of π to be 3.142 unless the question instructs otherwise.



Information

- The total mark for this paper is 80
- The marks for **each** question are shown in brackets – *use this as a guide as to how much time to spend on each question.*

Advice

- Read each question carefully before you start to answer it.
- Keep an eye on the time.
- Try to answer every question.
- Check your answers if you have time at the end.

Turn over ►

P62276A

©2020 Pearson Education Ltd.

1/1/1/

.CG Maths.

Hints



Pearson

Please note that these worked solutions have neither been provided nor approved by Pearson Education and may not necessarily constitute the only possible solutions. Please refer to the original mark schemes for full guidance.

Any writing in blue indicates what must be written in order to answer the questions and get the marks. The worked solutions have been designed to show the smallest amount of work which needs to be done to answer the question.

Anything written in green in a cloud doesn't have to be written in the exam.

Anything written in orange in a rectangle doesn't have to be written in the exam and is there to show what should be put into a calculator or measured using a ruler or protractor.

If you find any mistakes or have any requests or suggestions, please send an email to curtis@cgmaths.co.uk

Answer ALL questions.

Write your answers in the spaces provided.

You must write down all the stages in your working.

1 Change 300 centimetres into metres.

There are 100cm in 1m

..... metres

(Total for Question 1 is 1 mark)

2 Work out $\frac{1}{3}$ of 24

To work out $\frac{1}{3}$ of a number, divide it by 3

.....

(Total for Question 2 is 1 mark)

3 Write 40% as a fraction.

Percent means out of 100

.....

(Total for Question 3 is 1 mark)

4 Work out 2.5^2

Type into the calculator

.....

(Total for Question 4 is 1 mark)

5 Write the following numbers in order of size.
Start with the smallest number.

1 -4 0 7 -6 -3 2

The more negative or less positive
a number is, the smaller it is

.....

(Total for Question 5 is 1 mark)

DO NOT WRITE IN THIS AREA

DO NOT WRITE IN THIS AREA

DO NOT WRITE IN THIS AREA

6 The graph shows some information about car production in the UK over eight years.

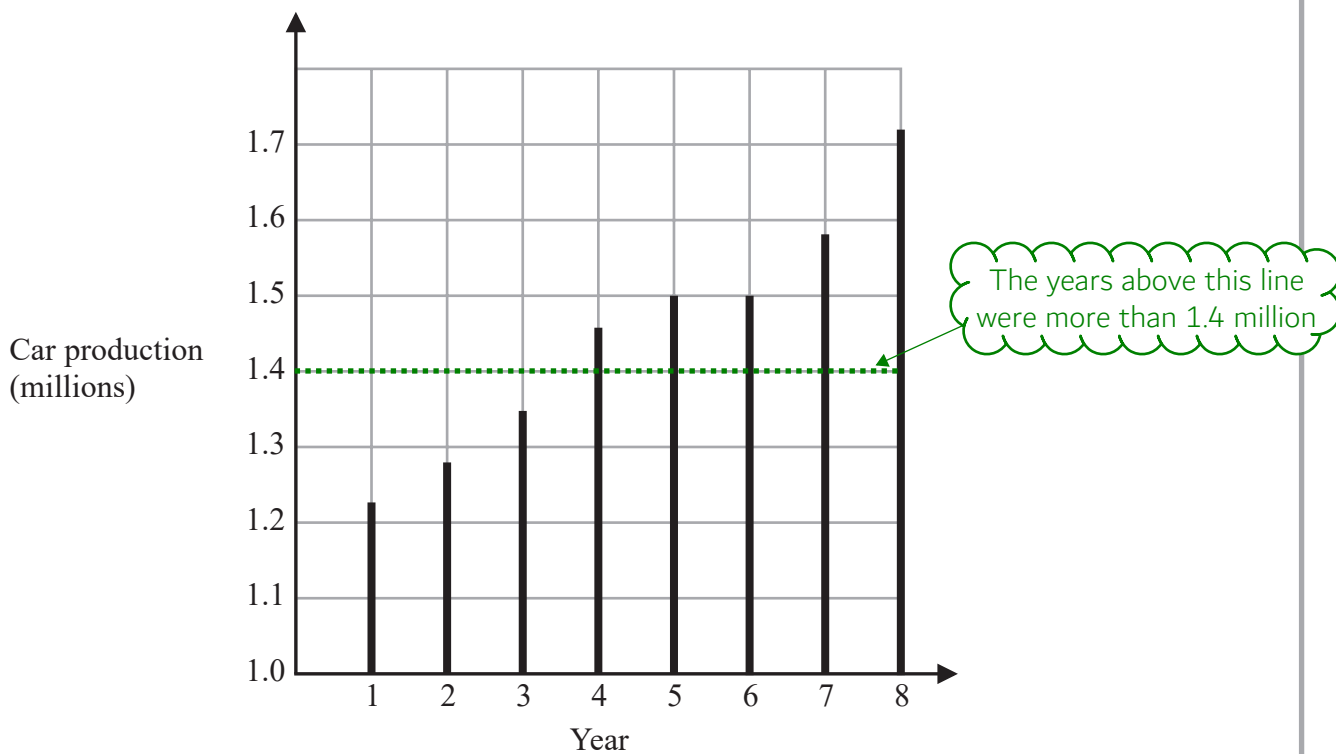

(a) For how many of these years was car production more than 1.4 million?

.....
(1)

(b) In which two years was car production the same?

The bars will be the same height

.....
(1)

(Total for Question 6 is 2 marks)

DO NOT WRITE IN THIS AREA

DO NOT WRITE IN THIS AREA

DO NOT WRITE IN THIS AREA

7

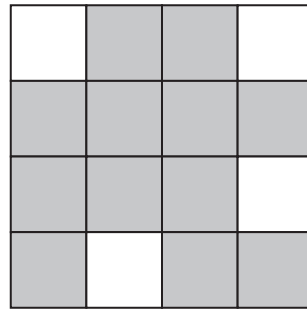

What fraction of the shape is shaded?
Give your answer in its simplest form.

12 out of the 16 squares are shaded

Entering the fraction into the calculator simplifies the fraction

.....
(Total for Question 7 is 2 marks)

8 Karim buys 200 tiles.

The tiles are sold in boxes.
There are 25 tiles in each box.
Each box of tiles costs £9.75

Work out the total cost of the boxes of tiles Karim buys.

Dividing the number of tiles by the number in each box works out how many boxes are needed. Multiplying this by the cost of each box gives the total cost of the boxes

£

(Total for Question 8 is 3 marks)

- 9 (a) Work out the value of $\frac{300}{2 \times 5}$

Type into calculator

.....
(1)

- (b) Work out the value of $(6 - 2.5)(8 + 4)$

Type into calculator

.....
(1)

- (c) Write down the reciprocal of 20

Reciprocal means 1 divided by

.....
(1)

(Total for Question 9 is 3 marks)

- 10 The graph shows information about the time, in minutes, a liquid has been cooling and the temperature of the liquid in $^{\circ}\text{C}$.

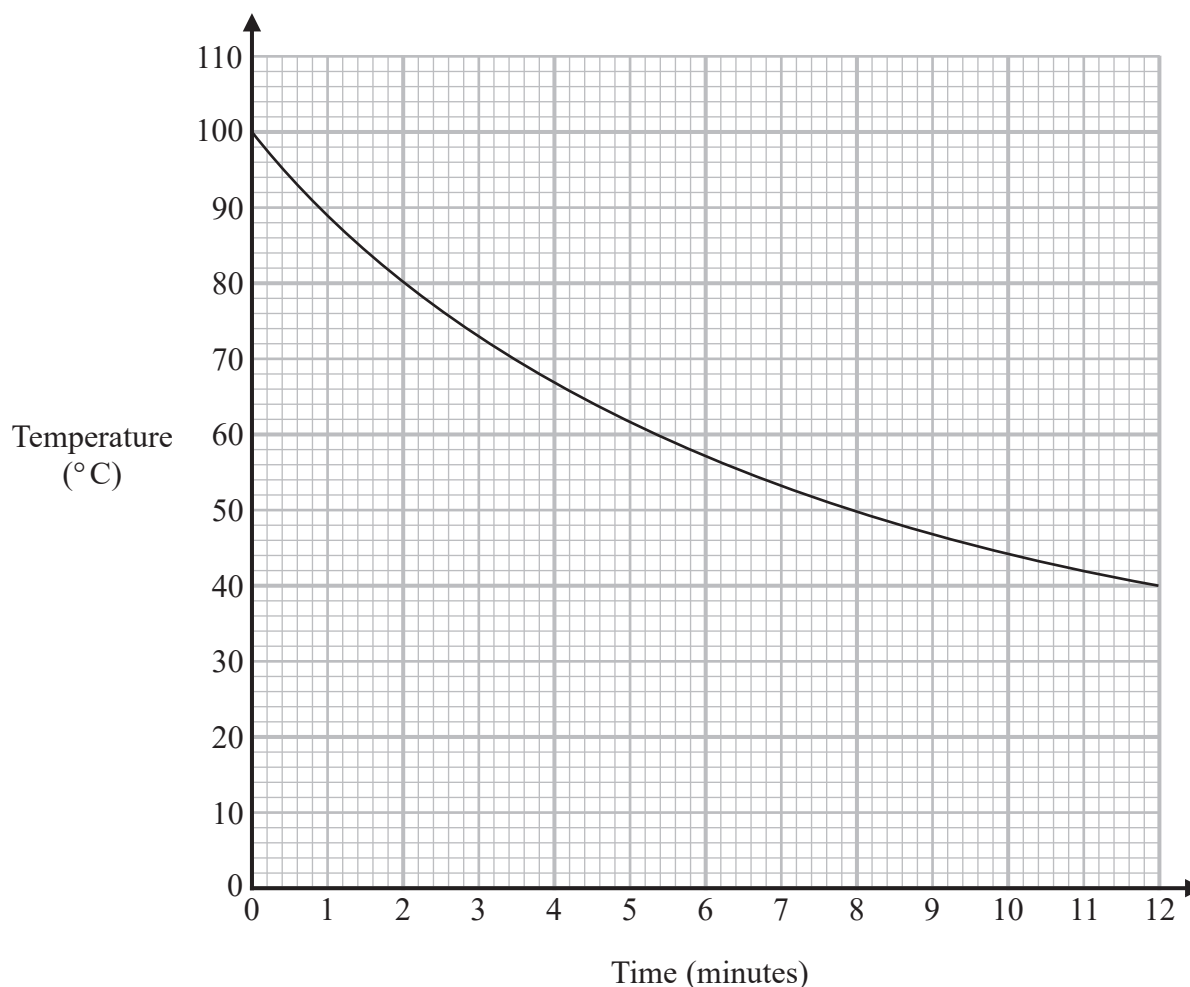

- (a) What is the temperature of the liquid at time 2 minutes?

Read up from 2 minutes to the line
then across to the temperature

..... $^{\circ}\text{C}$

(1)

Pam recorded the time when the liquid had a temperature of 50°C .

- (b) Write down this time.

Read across from 50°C to the
line then down to the time

..... minutes

(1)

Pam says that the temperature of the liquid drops more in the first 3 minutes of cooling than it does between time 9 minutes and time 12 minutes.

(c) Is Pam correct?

Give a reason for your answer.

The steeper the gradient, the faster the temperature is changing. The two ranges of time we are comparing are the same length of time

(1)

(Total for Question 10 is 3 marks)

- 11 $PQRS$ is a quadrilateral.
 PST is a straight line.

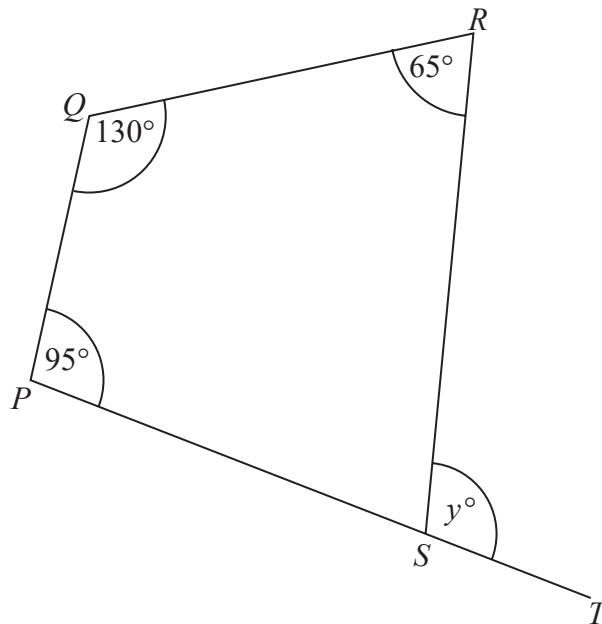

Find the value of y .

Angles around a point on a straight line add to 180.
There are 360 degrees in total in a quadrilateral

$y = \dots\dots\dots$

(Total for Question 11 is 3 marks)

12 Here are the first five terms of a number sequence.

45 40 35 30 25

(a) (i) Write down the next two terms of this sequence.

It goes down 5 between each term

.....
(1)

A term of this sequence is -5

(ii) Which term?

On the calculator, enter 45 then press =. Enter ANS - 5 and keep pressing = until we reach -5. Count how many times it takes: it is this many terms after the first term

.....
(1)

The n th term of a different sequence is given by the expression $4n + 3$

(b) Find the 9th term of this sequence.

On the 9th term, $n = 9$. Substituting this into the expression works out the 9th term

.....
(1)

(Total for Question 12 is 3 marks)

DO NOT WRITE IN THIS AREA

DO NOT WRITE IN THIS AREA

DO NOT WRITE IN THIS AREA

13

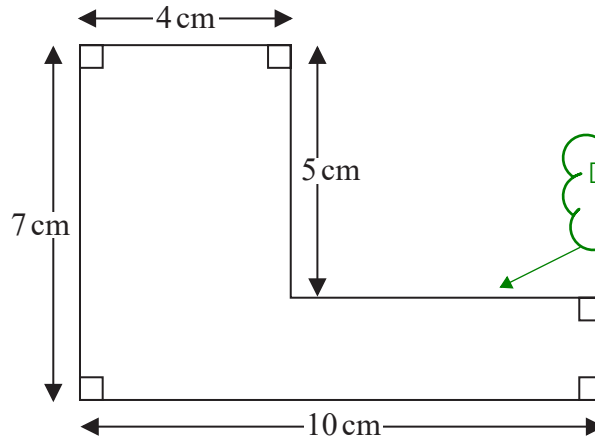

Don't forget the two missing sides which aren't given

Work out the perimeter of this shape.

The perimeter is all of the outside lengths added together

..... cm

(Total for Question 13 is 2 marks)

14 (a) Simplify $3x + 5y + 2x - 4y$

Collecting the like terms gives $3x + 2x + 5y - 4y$

..... (2)

(b) Solve $5p + 7 = 22$

Follow BIDMAS backward to decide what to get rid of first. Do opposite operations to both sides to get rid of everything apart from p on the left side

$p =$ (2)

(Total for Question 14 is 4 marks)

15 Here are the costs of the same type of batteries in two shops.

Shop A
Pack of 4 batteries
£1.60

Shop B
Pack of 6 batteries
£2.70

Harry needs to buy at least 30 batteries.

He assumes that he has to buy batteries in whole packs.

Harry wants to buy the batteries as cheaply as possible from the same shop.

(a) Which shop should he buy the batteries from, shop A or shop B?

You must show all your working.

Work out how many lots of 4 and 6 go into 30. Round up to a whole number to get the number of packs needed to get at least 30 batteries. Then multiply this number of packs by the price per pack for each shop. The lowest price is the shop he should buy them from

(4)

Harry's assumption is wrong.

He can buy single batteries for 40p each in shop A and for 45p each in shop B.

(b) Does this affect which of these two shops Harry should buy the batteries from?

Give a reason for your answer.

It is the same price per battery to buy them in packs as it is to buy them individually. Consider that if more than 30 batteries were bought it might work out cheaper to buy some single batteries rather than an extra pack to get to at least 30

(1)

(Total for Question 15 is 5 marks)

16 There are only 5 blue cards, 2 green cards and 4 red cards in a pack.

Isabella is going to take at random one card from the pack.

(a) Write down the probability that Isabella will take a blue card.

There are ... cards in total. Out of these, there are 5 blue cards

.....
(2)

Ken is going to throw a biased dice once.
The probability that the dice will land on six is 0.3

(b) What is the probability that the dice will **not** land on six?

It is certain to either land on six or not land on six so the probabilities must add to 1

.....
(1)

(Total for Question 16 is 3 marks)

- 17 Draw accurately an isosceles triangle with sides of length 8 cm, 6 cm and 6 cm.
One side of the triangle has been drawn for you.

Using a compass, scribe arcs with a radius of 6cm from both ends of the 8cm line.
Draw lines using a ruler from the ends of the 8cm line to where the arcs cross

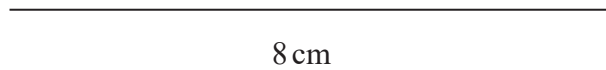

(Total for Question 17 is 2 marks)

DO NOT WRITE IN THIS AREA

DO NOT WRITE IN THIS AREA

DO NOT WRITE IN THIS AREA

DO NOT WRITE IN THIS AREA

DO NOT WRITE IN THIS AREA

DO NOT WRITE IN THIS AREA

18 This graph can be used to change between US dollars (\$) and British pounds (£).

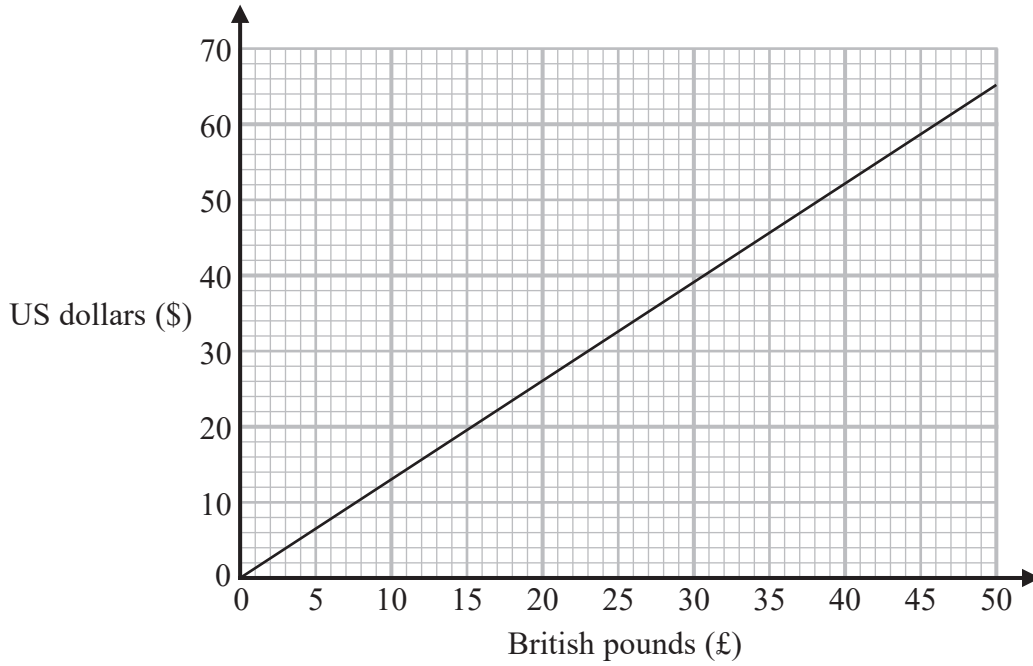

Rosie bought a ring in the USA.
She paid 345 US dollars.

Work out in pounds the amount Rosie paid for the ring.

Pick a convenient point on the graph where the line goes through grid lines for both the pounds and dollars, preferably as high up as possible to reduce any error. We will get \$x = £y. Every lot of \$x the \$345 is will be a lot of the £y

£

(Total for Question 18 is 3 marks)

19 Here are the types of sandwiches sold in a cafe last week.

Sandwiches
Tuna
Cheese
Chicken
Egg

56 tuna sandwiches were sold.

This was 40% of the total number of sandwiches sold.

(a) Work out the total number of sandwiches sold.

Let y be the total number of sandwiches. 40% as a decimal is 0.4 so multiplying y by this finds 40% of the total number of sandwiches. Make an equation in terms of y then solve the equation for y

.....
(2)

Of the 56 tuna sandwiches sold, 18 were sold on Friday.

(b) Write 18 as a percentage of 56

Give your answer correct to the nearest whole number.

Express 18 as a fraction of 56 then convert it into a percentage by working out this fraction of 100

..... %
(2)

(Total for Question 19 is 4 marks)

20 Akhtar, Ben and Carl each have some money.

Akhtar has £65

Ben has £100

Carl has three £5 notes, one £20 note and some £10 notes.

The mean amount of money per person is £80

How many £10 notes does Carl have?

Mean = total/number, so total = mean x number. Multiplying the mean of 80 by the number of people gives the total amount of money. Subtracting the amount of money Akhtar and Ben have and the three £5 notes and one £20 Carl has leaves the amount of money made by the £10 notes. Work out how many lots of £10 this is

.....
(Total for Question 20 is 4 marks)

21 Malik is going to throw a fair coin 50 times.

(a) Write down an estimate for the number of times the coin will land on heads.

Multiplying the probability of heads by the number of times the coin is thrown gives an estimate of the number of times the coin will land on heads

(1)

Paula and Simon are trying to find out if a different coin is biased.

Paula throws this coin 10 times.

She records the number of times the coin lands on heads.

Simon throws the same coin 100 times.

He records the number of times the coin lands on heads.

(b) Whose results will be more useful in deciding if the coin is biased?

Give a reason for your answer.

The more times the coin is thrown, the more likely the relative frequency of heads is to be an accurate estimate of the probability it will be heads. The estimated probability of a heads could be used to decide if the coin is likely to be biased

(1)

(Total for Question 21 is 2 marks)

DO NOT WRITE IN THIS AREA

DO NOT WRITE IN THIS AREA

DO NOT WRITE IN THIS AREA

22 Here is a solid made from a square-based pyramid and a cube.
Each edge of the solid has length 6 cm.

It is easiest to start by drawing these edges then drawing the slanted edges of the pyramid

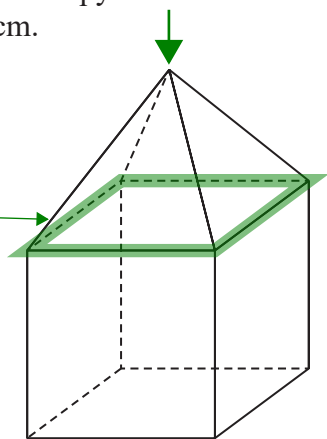

The plan is the view from above

On the centimetre grid, draw the plan of this solid.

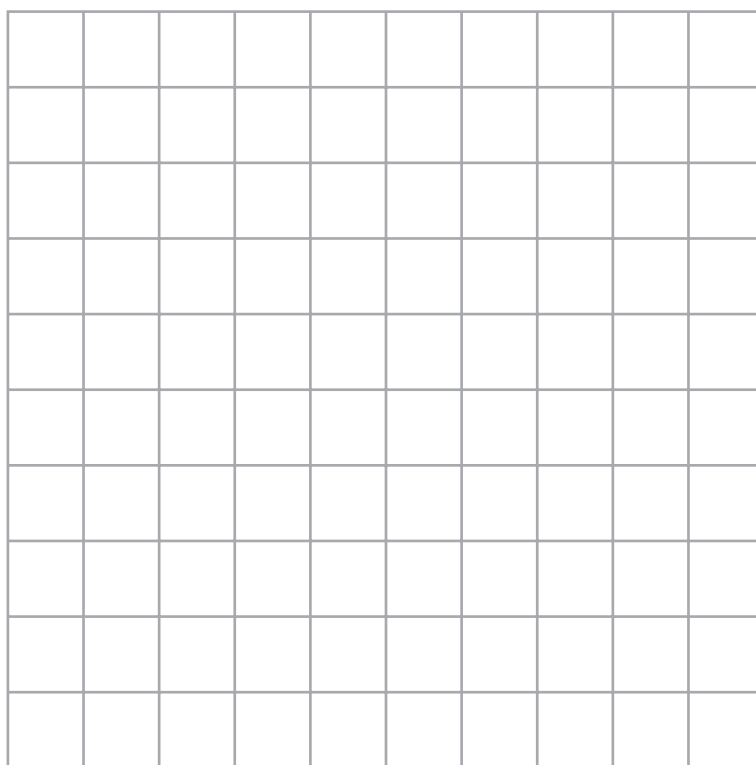

(Total for Question 22 is 2 marks)

23 (a) Simplify $n^3 \times n^5$

$$a^x \times a^y = a^{x+y}$$

.....
(1)

(b) Simplify $\frac{c^3d^4}{c^2d}$

$$a^x/a^y = a^{x-y}$$

d is basically d^1

.....
(2)

(c) Solve $\frac{5x}{2} > 7$

This inequality solves in a similar way to an equation. Do the opposite operation to both sides of the inequality until x is on its own

.....
(2)

(Total for Question 23 is 5 marks)

DO NOT WRITE IN THIS AREA

DO NOT WRITE IN THIS AREA

DO NOT WRITE IN THIS AREA

24 Andy cycles a distance of 30 km at an average speed of 24 km/h.
 He then runs a distance of 12 km at an average speed of 8 km/h.

Work out the total time Andy takes.
 Give your answer in hours and minutes.

s d t

This is a distance, speed, time problem so we can start with writing the formula triangle

Use the formula triangle to work out the formula for time. Adding the two times gives the total time

FACT B Convert the total time from hours to hours and minutes by pressing the button on the left

..... hours minutes

(Total for Question 24 is 3 marks)

25 A number, m , is rounded to 1 decimal place.
 The result is 9.4

Complete the error interval for m .

Add and subtract half of the resolution to get the upper and lower bounds. The resolution is 0.1 as it is to 1 decimal place

Lower bound $\leq m <$ Upper bound

(Total for Question 25 is 2 marks)

26 Maisie knows that she needs 3 kg of grass seed to make a rectangular lawn 5 m by 9 m.

Grass seed is sold in 2 kg boxes.

Maisie wants to make a rectangular lawn 10 m by 14 m.

She has 5 boxes of grass seed.

(a) Has Maisie got enough grass seed to make a lawn 10 m by 14 m?

You must show all your working.

Area of rectangle = length \times width. Work out the area of the lawn she wants and the area of the lawn made by 3kg of grass seed. Work out how many lots of the area of the lawn made by 3kg of grass seed goes into the area of the lawn she wants. This many lots of 3kg are needed to make the lawn she wants. Work out the mass of the grass seed needed. Work out how many boxes this would need. Compare this to the 5 boxes she has to decide if she has enough

(4)

Maisie opens the 5 boxes of grass seed.

She finds that 4 of the boxes contain 2 kg of grass seed.

The other box contains 1 kg of grass seed.

(b) Does this affect whether Maisie has enough grass seed to make her lawn?

Give a reason for your answer.

1kg is half of 2kg so is worth half of one of the original boxes the calculation to the previous question was based on

(1)

(Total for Question 26 is 5 marks)

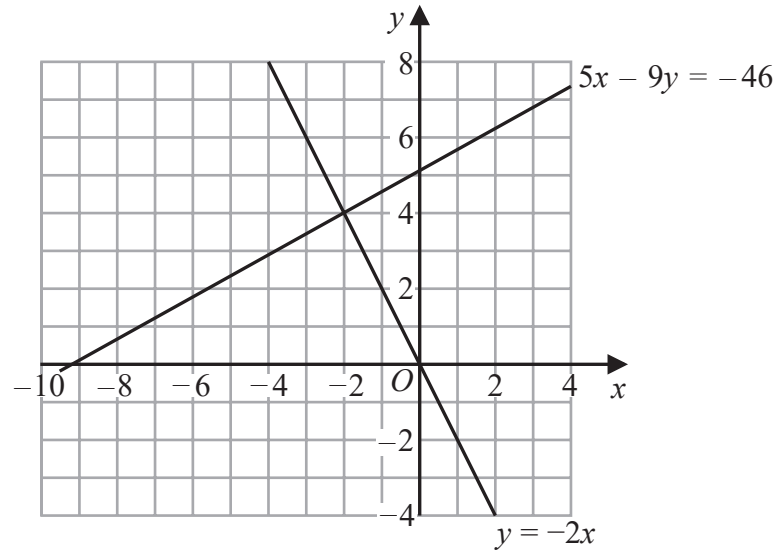

(a) Use these graphs to solve the simultaneous equations

$$\begin{aligned} 5x - 9y &= -46 \\ y &= -2x \end{aligned}$$

The solutions are where the graphs cross as the x and y coordinates satisfy both equations at the same time at that point

$$x = \dots\dots\dots$$

$$y = \dots\dots\dots$$

(1)

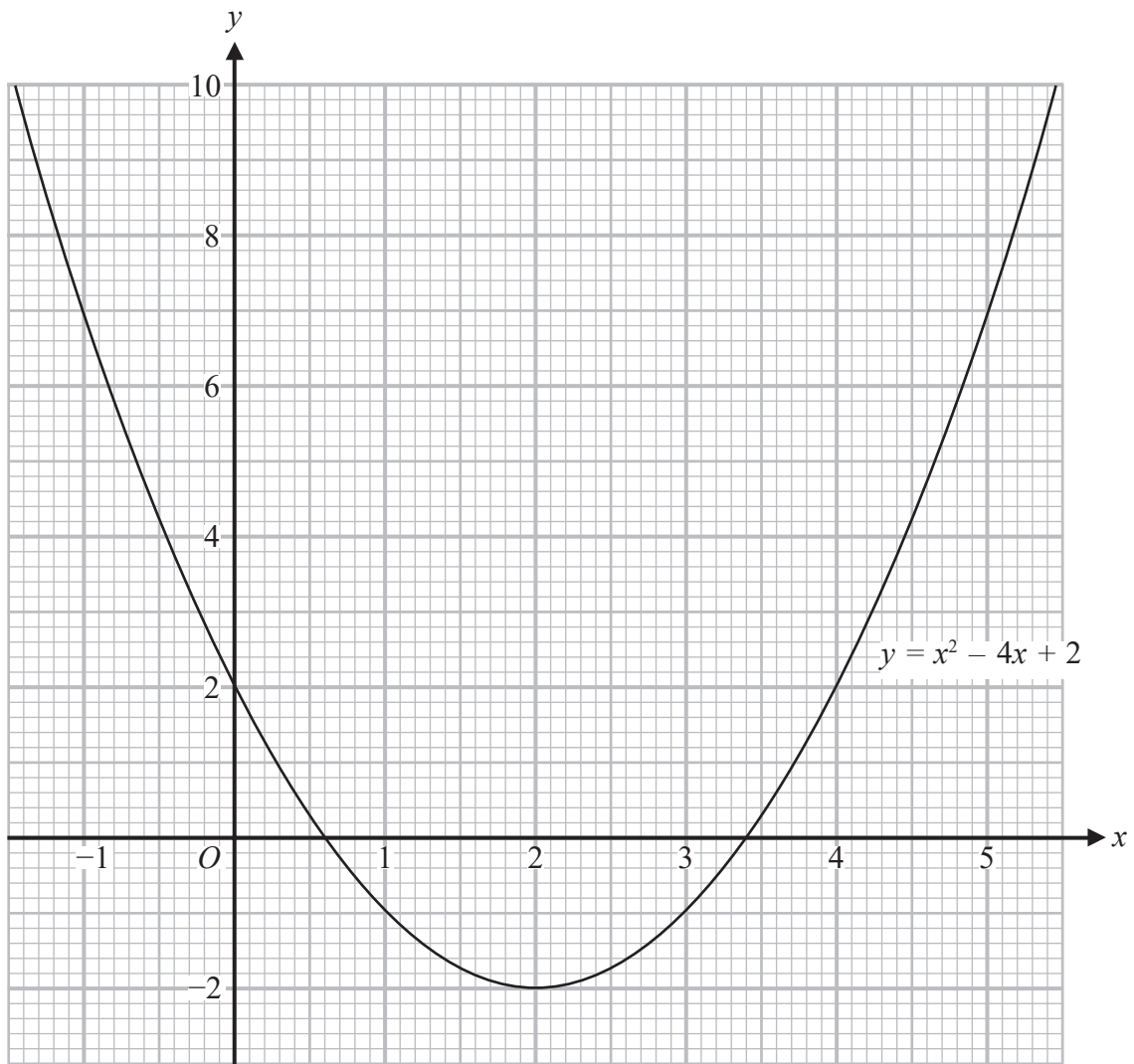

(b) Use this graph to find estimates for the solutions of the quadratic equation $x^2 - 4x + 2 = 0$

It is basically asking what x is when y = 0

(2)

(Total for Question 28 is 3 marks)

DO NOT WRITE IN THIS AREA

29 The diagram shows a solid triangular prism.

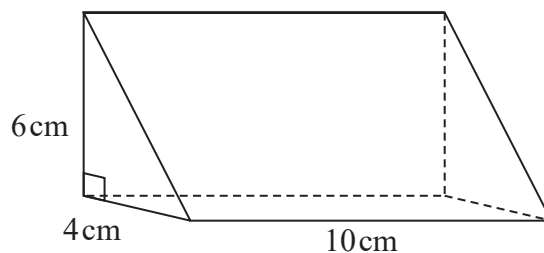

The prism is made from wood with a density of 0.8 g/cm^3

Work out the mass of this prism.

$d^m v$

This is a density, mass, volume problem so starting with writing the formula triangle

Work out the formula for mass using the formula triangle.
 Volume of prism = (cross sectional area) \times length.
 The cross section is a triangle.
 Area of triangle = $\frac{1}{2} \times \text{base} \times \text{height}$

g

(Total for Question 29 is 3 marks)

TOTAL FOR PAPER IS 80 MARKS