

**Level 2 Functional Skills Mathematics
SAMPLE PAPER 2**

**Duration: 25 minutes
Total marks: 15 marks**

SECTION 1 – CALCULATOR NOT PERMITTED

Candidate name (first, last)

First

Last

Candidate enrolment number

Date of birth (DDMMYYYY)

Assessment date (DDMMYYYY)

Centre number

Candidate signature and declaration*

***I declare that I had no prior knowledge of the questions in this assessment and that I will not share information about the questions.**

**Please check that your name is correctly printed on the candidate barcode label.
If not, please tell the invigilator before the start of the exam.**

You should have the following for this assessment:

- a pen with black or blue ink
- a pencil (for diagrams, graphs and charts only)
- an eraser
- a 30cm ruler.

You must NOT use a protractor.

You must NOT use a calculator for Section 1.



General instructions

- Read through each question carefully.
- Write all your answers in this booklet.
- Check your calculations and check that your answers make sense.

.CG Maths.

Hints



Please note that these worked solutions have neither been provided nor approved by City & Guilds and may not necessarily constitute the only possible solutions. Please refer to the original mark schemes for full guidance.

Any writing in blue indicates what must be written in order to answer the questions and get the marks. The worked solutions have been designed to show the smallest amount of work which needs to be done to answer the question.

Anything written in green in a cloud doesn't have to be written in the exam.

Anything written in orange in a rectangle doesn't have to be written in the exam and is there to show what should be put into a calculator or measured using a ruler or protractor.

If you find any mistakes or have any requests or suggestions, please send an email to curtis@cgmaths.co.uk

SECTION 1 – CALCULATOR NOT PERMITTED

There are **15** marks available in this section.

You should check all your work as you go along.

You must **not** use a calculator in this section.



Q1

What is 108 as a fraction of 648? Give your answer in its simplest form.

108 as a fraction of 648 is $108/648$. The fraction is simplified by keep dividing the numerator and denominator by the same amount until they cannot be divided any further

$$\frac{\square}{\square}$$

(1 mark)

Q2

Which one of the following lists is in decreasing order?

(tick one box)

A $\frac{1}{5}$ 0.05 $\frac{17}{50}$ 0.15

B 0.05 $\frac{17}{50}$ $\frac{1}{5}$ 0.15

C 0.15 $\frac{1}{5}$ 0.05 $\frac{17}{50}$

D $\frac{17}{50}$ $\frac{1}{5}$ 0.15 0.05

Convert $1/5$ and $17/50$ into decimals by dividing the numerators by the denominators. This makes all the values easier to compare

(1 mark)

Q3 The diagram shows a regular polygon.

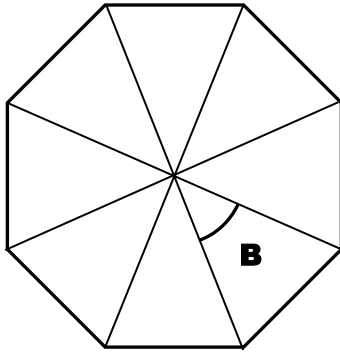

What is the size of angle B.

_____°

(1 mark)

There are 8 identical angles around the point at the centre. There are 360° around a point

Q4

Work out the value of y if $4y = 144$

Dividing both sides by 4 makes y the subject and gives $y = 144/4$

(1 mark)

Q5

$$\frac{3^2}{3} - 28 =$$

Deal with the 3^2 first then divide the result by the 3. $3^2 = 3 \times 3$

(1 mark)

.CG Maths.

Q6 The radius of the top of this cylinder is 7cm

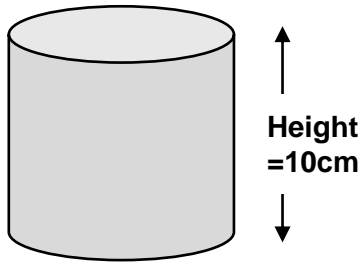

Use $\pi = \frac{22}{7}$

What is the volume of the cylinder?

A cylinder is like a prism so volume = cross sectional area x length. The length is 10cm. The cross section is a circle and area of circle = $\pi \times \text{radius}^2$ _____ cm³

(1 mark)

Q7

$$\frac{11}{8} - \frac{1}{16} =$$

(tick one box)

A $\frac{5}{8}$

B $1\frac{5}{8}$

C $1\frac{5}{16}$

D $2\frac{5}{16}$

Make the denominators the same by multiplying both the numerator and denominator of $11/8$ by the same amount. Then the numerators can be subtracted and the denominator stays the same. Convert the result into a mixed fraction by dividing the numerator by the denominator to get the whole number and leave the remainder in the fraction

(1 mark)

Q8

$$4.50 \div 0.05 =$$

Considering the division as the fraction $4.50/0.05$, multiplying both the numerator and denominator by something gets rid of the decimal on the denominator and makes the division easier

(1 mark)

.CG Maths.

Q9

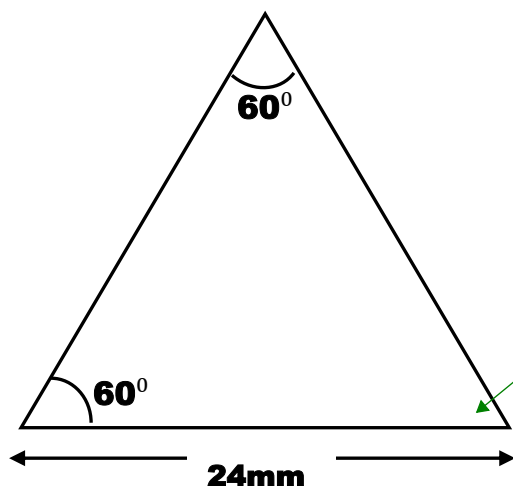

Diagram not to scale

Find this missing angle to decide what type of triangle it is

What is the perimeter of this triangle?

Perimeter is the total of all of the outside edges

_____ mm

(1 mark)

Q10 A call centre aims to deal with calls in less than 5 minutes.

Calls come in randomly.

The table shows data for the calls made to the centre.

| Type of call | Proportion of all calls | Completed in less than 5 minutes |
|---------------------|-------------------------|----------------------------------|
| Customer complaints | $\frac{1}{4}$ | $\frac{1}{2}$ |
| New business | $\frac{3}{4}$ | $\frac{1}{8}$ |

Work out the probability that the next call will be a customer complaint completed within under 5 minutes.

Give your answer as a fraction in its simplest form.

$\frac{1}{2}$ of $\frac{1}{4}$ of the calls are customer complaints completed within under 5 minutes. 'Of' means to multiply. To multiply fractions, multiply the numerators and denominators

| |
|----------------------|
| <input type="text"/> |
| <hr/> |
| <input type="text"/> |

(1 mark)

.CG Maths.

Q11 The government announces that the minimum wage for people over 25 years old will increase from £8.21 to £8.72 per hour.

A 26 year old woman works 30 hours a week and is paid the minimum wage.

She thinks that the extra money she will earn will cover a rent increase of £20 per week.

Is the woman correct? Show your calculation.

Decision (tick one) **yes** **no**

Calculation

Working out the increase in hourly pay then multiplying this by the 30 hours worked per week gives the increase in wage per week

(1 mark)

Q12 A driver sees this speed limit sign in France. The speed is in kilometres per hour.



He is driving at 80 miles per hour.

$$1 \text{ kilometre} = \frac{5}{8} \text{ mile}$$

He thinks this is below the speed limit.

Is he correct? Explain your answer showing your calculation.

Decision (tick one box) **yes** **no**

Explanation

Every $\frac{5}{8}$ of a mile is 1 kilometre so dividing 80km by $\frac{5}{8}$ converts it into miles. Both units are per hour so we can ignore this part and focus on the distance. To divide by a fraction, keep the first number, change the sign to a multiply, flip the second fraction. To multiply by a fraction, divide by the denominator then multiply by the numerator

(2 marks)

.CG Maths.

Q13 A man has a fish tank with the following dimensions:

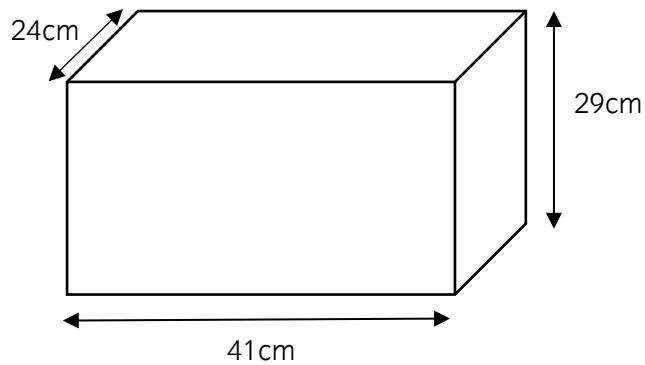

He needs to know approximate volume of the tank.

What is its approximate volume?

Volume of cuboid = length \times width \times height. Round each to 1 significant figure, which means to round the first figure using the second figure then set everything after the first figure to 0 and ignore them

_____ cm^3

(2 marks)

End of Section 1